

Adjusting the carriage locking (brake) mechanism

1. Remove the deflecting device as above
2. Loosen the setscrew for the backing screw (also on the left side of the carriage-shown just below the "Striebig" nameplate in the drawing)
3. Make adjustment to the backing screw #32 from behind with 6mm Allen wrench so that the screw just touches the back rail, then back off a minute amount, and tighten setscrew.
4. For front locking lever adjustment refer to # 30
5. Loosen center screw and remove.
6. While pulling out handle, rotate either clockwise or counterclockwise until carriage can be locked in place securely and lever can be rotated counterclockwise horizontally.
7. Replace and tighten center screw.

Motorlaufwagen

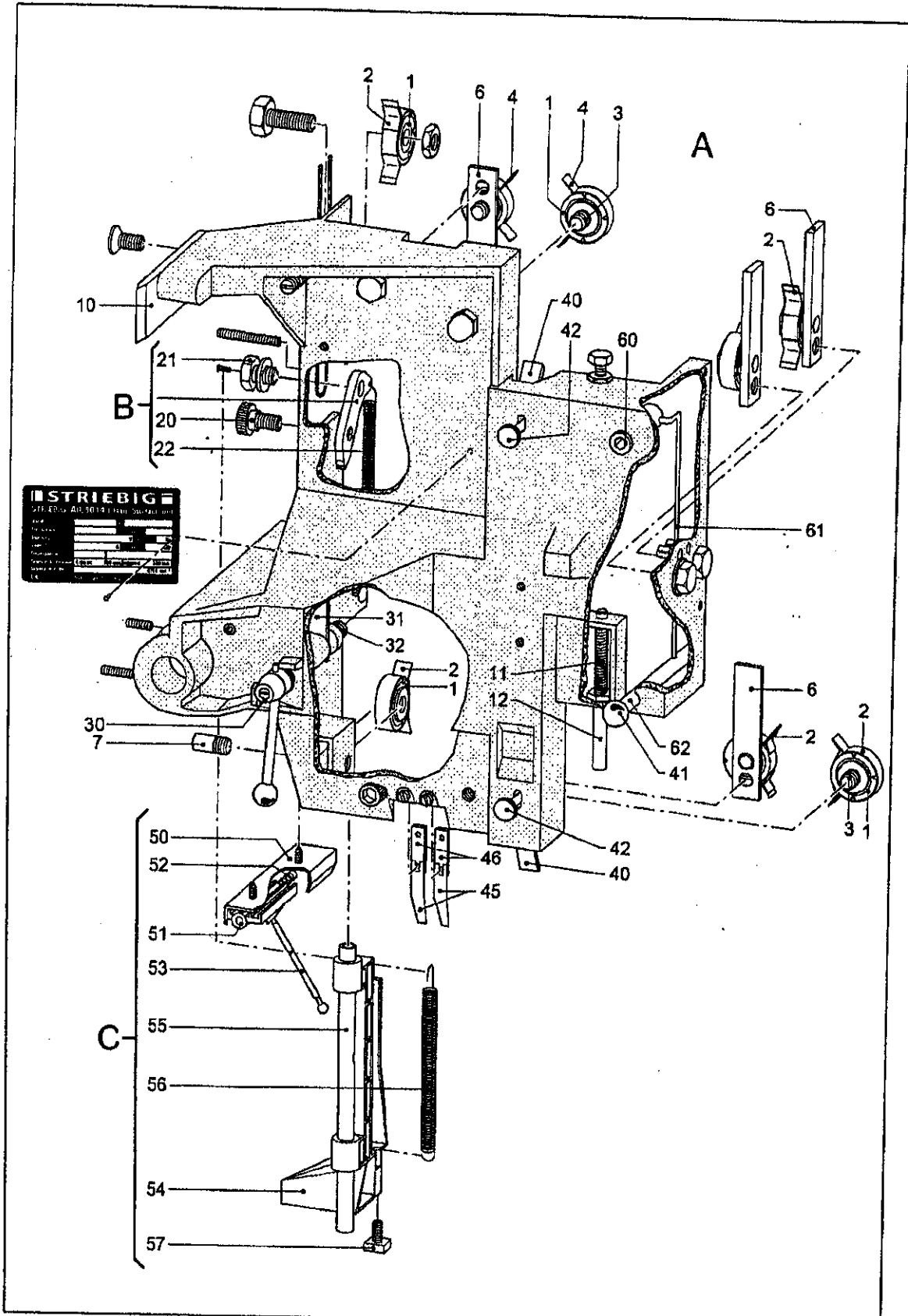

87/220 J119